

Programmer Studio 6.0

SOFTWARE DEVELOPMENT KIT

The Agilio® P4C SDK 6.0 accelerates solution time-to-market by providing engineering teams with powerful designs and development tools for software customization in the data plane of Corigine's SmartNICs. The Programmer Studio in the Agilio P4C SDK 6.0 is the industry's first P4 and C GUI-based Integrated Development Environment (IDE) for dynamically programming new and innovative networking capabilities on the Agilio CX and LX family of SmartNICs. Designers will benefit from an intuitive software development environment including tools for P4 development and a C-compiler both optimized for Corigine's Network Flow Processors (NFPS) offering a cycle-accurate simulator and extensive profiling capability for rapid debugging and prototyping.



Details

Programmer Studio IDE

- Supports Corigine Agilio CX and LX SmartNICs
- Project Creation
- Incorporation of all project components
 - Sources (P4, C and Assembly)
 - Headers
 - Macros
 - Standard Libraries
 - Scripts

Code Development Tools

- P4 Compiler
- Network Flow C Compiler (NFCC)
- Network Flow Assembler (NFAS)

Optional Flow Processing Software

- Software Application Kits
- Software Building Blocks
- Sample Code (example applications)
- MicroC and Assembly Libraries
- Standard Packet Processing APIs

KEY FEATURES

- Optimized language processors designed to combine P4 or C-level abstraction and assembly level bare metal control and performance
- Cycle-accurate chip simulation presented in an intuitive graphical format, enabling efficient software development efforts
- Hardware debugger for Corigine Agilio SmartNICs using Programmer Studio
- Board support package (BSP) API integration for simplified and easier board bring up with Agilio SmartNICs
- User-friendly work environment with project-based source, header, macro, and script collection and tracking
- Throughput, code coverage and event profiling tools for precise optimization
- Reference applications for the Agilio CX and Agilio LX SmartNICs for project creation and simulations

- Linux Simulator and tool chain with Compiler, Assembler and Linker

Precision Flow Modeler Simulation

- Debug
 - Cycle-accurate data history
 - Cycle-accurate core execution history
 - Cycle-accurate event and queue history
- Profiling
 - Per-thread performance statistics
 - FIFO space coverage
 - Per-thread execution coverage profiling
 - Per-port frame and byte performance
 - Bandwidth estimates

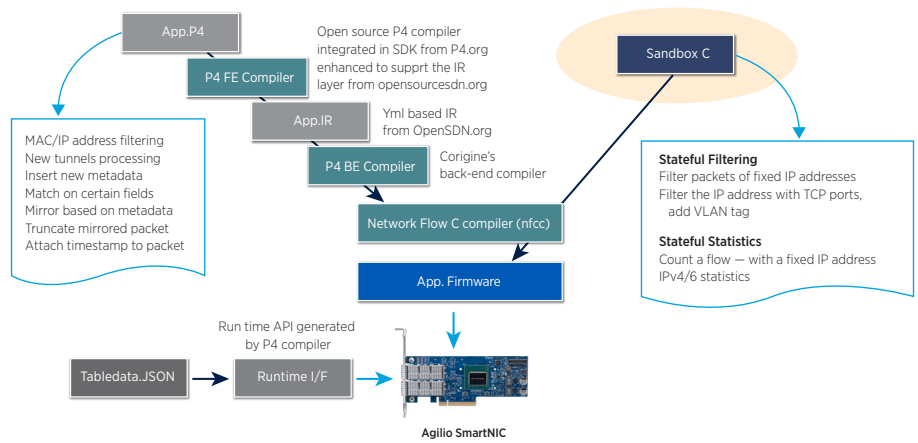

Corigine's fully Integrated Development Environment (IDE) enables developers to speed the time-to-market for their products and applications.

Hardware Debug

- Debug Server enables direct connection between Programmer Studio IDE and HW targets
 - Corigine Agilio SmartNICs
- Debug Server runs from host of off PCIe bus

Accessories

- Linker
- Loader
- BSP with system access API and Linux kernel host layer for Agilio SmartNIC platforms.

Specifications

- Included in the Agilio P4C SDK:
 - Programmer Studio IDE
 - P4 Compiler
 - C Compiler (NFCC)
 - MicroC Libraries
 - Assembly Libraries
 - Precision Flow Monitor Simulation
 - Assembler (NFAS)
 - Linux Boards Support Package
 - Detailed documentation and user guides

Requirements

- 2.2 GHz (x86) with 8GB RAM and 2 GB of available hard drive space. 64 bit Windows 7 or Windows 8/8.1.
- Linux – Quad Core i7 with CentOS 6 64-bit or Ubuntu 12.04.2/14.04 x 64-bit LTS with 8GB RAM.

Corigine

Email: sales@corigine.com
www.corigine.com.cn

©2020 Corigine. All rights reserved.

Corigine, the Corigine logo are trademarks or registered trademarks of Corigine. All other trademarks mentioned are registered trademarks or trademarks of their respective owners in the United States and other countries.

PB-PROG-STUDIO6-7/20